

REVISIONS		DESCRIPTION\DATE
ISS	SYMBOL	

REMARK: RoHS COMPLIANT

FOR CUSTOMER

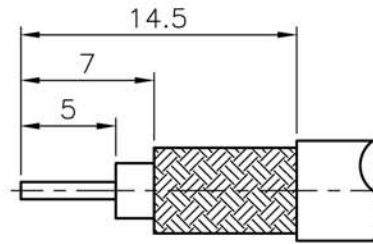

RECOMMENDED  
CABLE STRIPPING DIM'S

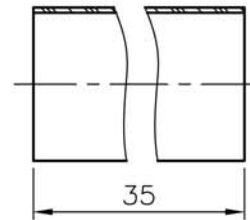
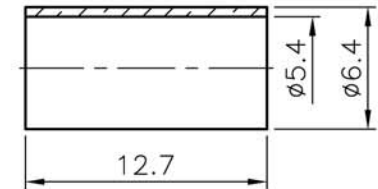
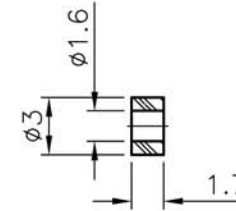
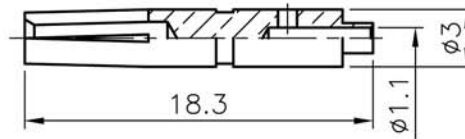
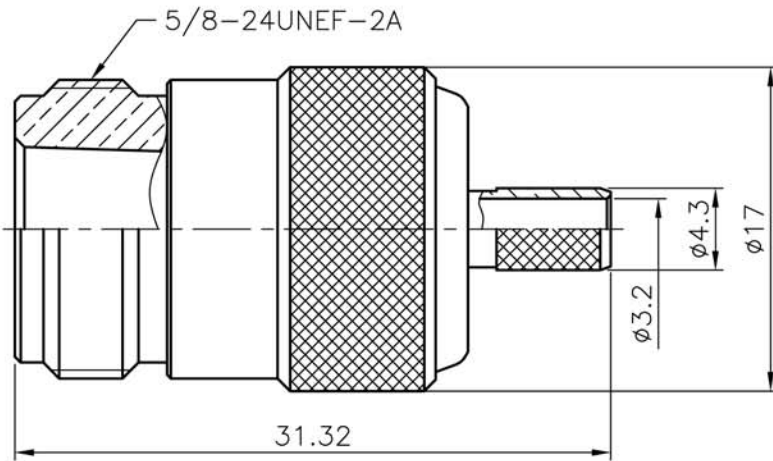

NOTES: FINISH (PLATING THICKNESS IN MICRO-INCHES)

1. BRASS PER QQ-B-626
2. NICKEL PL 70 MIN THICK OVER COPPER STRIKE
3. GOLD PL 3 MIN OVER NICKEL PL 70 MIN THICK OVER COPPER STRIKE
4. TEFLON MIL-P-19468
5. PHOSPHOR BRONZE PER QQ-B-750
6. BRASS JIS H 3250, C 2700

1. CRIMPED FERRULE  
HEX CRIMP SIZE .213" (5.41mm)

2. CRIMPED CONTACT PIN  
HEX CRIMP SIZE .100" (2.54mm)

NO.	DESCRIPTION	MATERIAL	FINISH	Q'TY	DRAWING NO.	SCALE	2.5/1	ISSUE	A1	PART NO.	CON-06-195	TerraWave Solutions
	HEAT SHRINK TUBE		BLACK			DIMENSIONS ARE IN MILLIMETERS				APPROVED	DATE	TITLE
	FERRULE	NOTE 6	NOTE 2			UNLESS OTHERWISE SPECIFIED TOLERANCES				CHECKED	DATE	N-Style Jack for TWS-195 Cable
	SPACER	NOTE 4	WHITE			0.5~6 = ±0.2				DRAWN	DATE	DRAWING NO.
	CONTACT PIN	NOTE 5	NOTE 3			>6~30 = ±0.4						FILE NO.
	BRAID HOLDER	NOTE 1	NOTE 2			>30~120 = ±0.6						
	INSULATOR	NOTE 4	WHITE			>120~315 = ±1						
	BODY	NOTE 1	NOTE 2			>315~1000 = ±1.6						
						ANGLES = ±5°						